

LUX CORPORATION, JAPAN



AUTOMATIC DIRECT-DRIVE PLAYER SYSTEM

PD 277

OWNER'S MANUAL

Thank you for purchasing the PD277

The PD277 is an automatic disc player using a Brushless & Slotless DC Servo Motor Direct-Drive system. Slots are completely removed to eliminate unevenness of rotation caused by electromagnetics, and further provided is a turntable platter of high inertia with which the large mass of platter weight is distributed around the outer contour, thus realizing excellent Wow & Flutter characteristics and stable rotation.

For the tonearm, a straight type is adopted to eliminate resonance caused by lack of solidity which tends to be found on the tonearm exclusively designed for high-compliance type cartridge. The root portion of the tonearm is of double-pipe structure to strengthen anti-resonance measures. Further, the cartridge shell is integrated to the tonearm, thus the resonance is suppressed down to the minimum.

The most salient feature of the PD277 is the Automatic Function. Unlike conventional automatic players, pure electronic tonearm operation system with an exclusive motor for tonearm provide quite smooth operation of the tonearm without sacrificing its inherent quality. The automatic function is not only convenient but protects records or cartridge stylus from accidental misuse.

Please read this Owner's Manual carefully before you proceed to its installation and use. This will help you realize the excellent capabilities of the PD277.



ASSEMBLY PROCEDURE

To protect the turntable from possible damage in the course of transportation, such heavy components as turntable platter, and main-weight of tonearm or acrylic cover which tend to slip out or be broken are packed separately from the main chassis. Further the motor and the transformer are firmly fixed to the chassis by means of clamping screws. Therefore correct assembly in accordance with the drawing is required. Correct assembly is of prime importance, since both the performance of your player system and the final tonal quality depend on it.

1. Turntable Platter

The turntable platter and the platter mat are housed at the bottom of the pack-

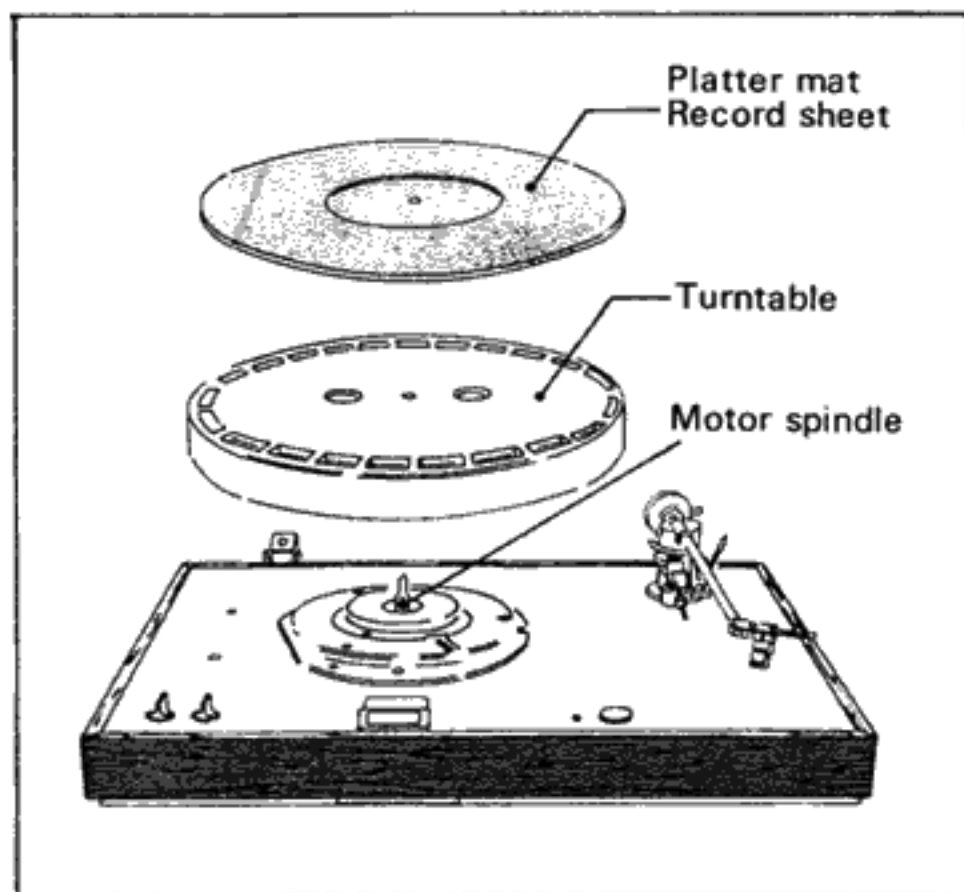

ing case. After having taken off the mat from the platter, insert carefully the platter in the center shaft of the motor, holding it by fingers through the 2 holes. Now turn the platter manually to check if correct setting-up is obtained. Then put the mat on the platter.

CAUTION:

Do this procedure carefully, since the turntable platter is very heavy. Rough handling may cause damage to the motor-shaft or the turntable itself.

2. Tonearm

[MAIN WEIGHT]

Take out the main-weight from the accessory compartment provided at the side of the packing case. Loosen the screw, then slide it into the counter-weight from the rear part of the tonearm. Again, tighten it.

[CARTRIDGE]

When you are going to use another cartridge, be careful about the lead connection: Four lead-wires are available at the shell, which are required to connect

to the cartridge. Connection should be done by color-discrimination as per the following guide:

WHITE L(+) (Hot-side of LEFT channel)

BLUE L(-) (Earth-side of LEFT channel)

RED R(+) (Hot-side of RIGHT channel)

GREEN R(-) (Earth-side of RIGHT channel)

Then install the cartridge to the shell by use of screws and nuts supplied with the cartridge. At this time, the over-hang adjustment should be done. This is to obtain a certain distance (15mm for the PD277) between the center of motor spindle and the stylus of the cartridge. Two screw-holes, whose center is positioned at 9mm from the stylus-point, are provided on the shell, and ± 2 mm is allowable for over-hang adjustment.

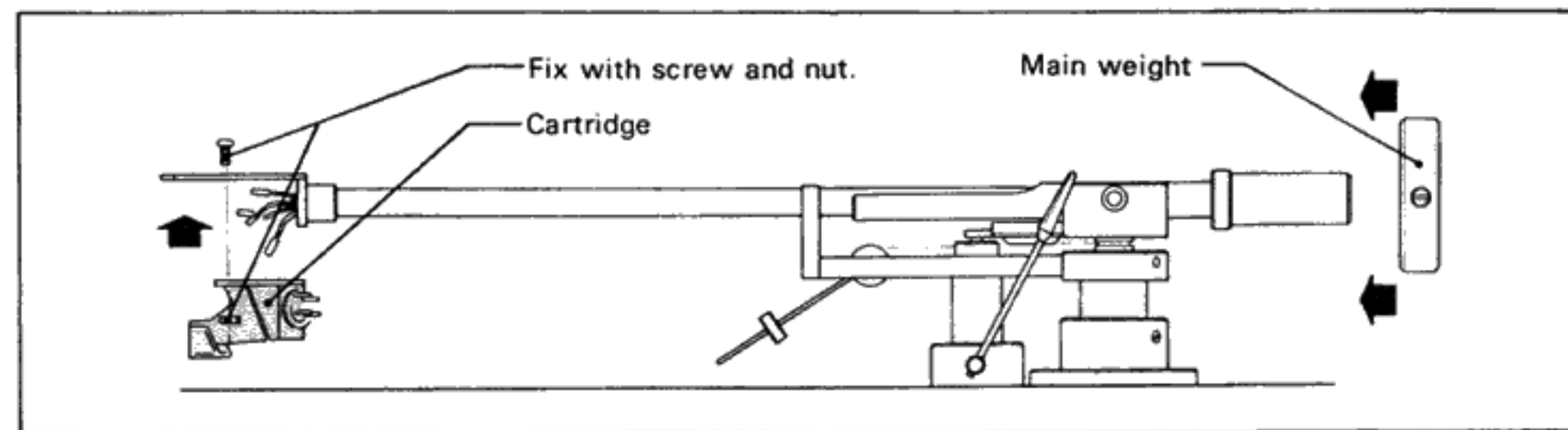

3. Dust Cover

This dust cover is detachable. For mounting, insert the projection on the hinge of the turntable into that of the dust cover, then slide the dust cover as per the drawing. Hold the dust cover at the hinge and fix it firmly. To remove the cover, slide it in the reverse direction.

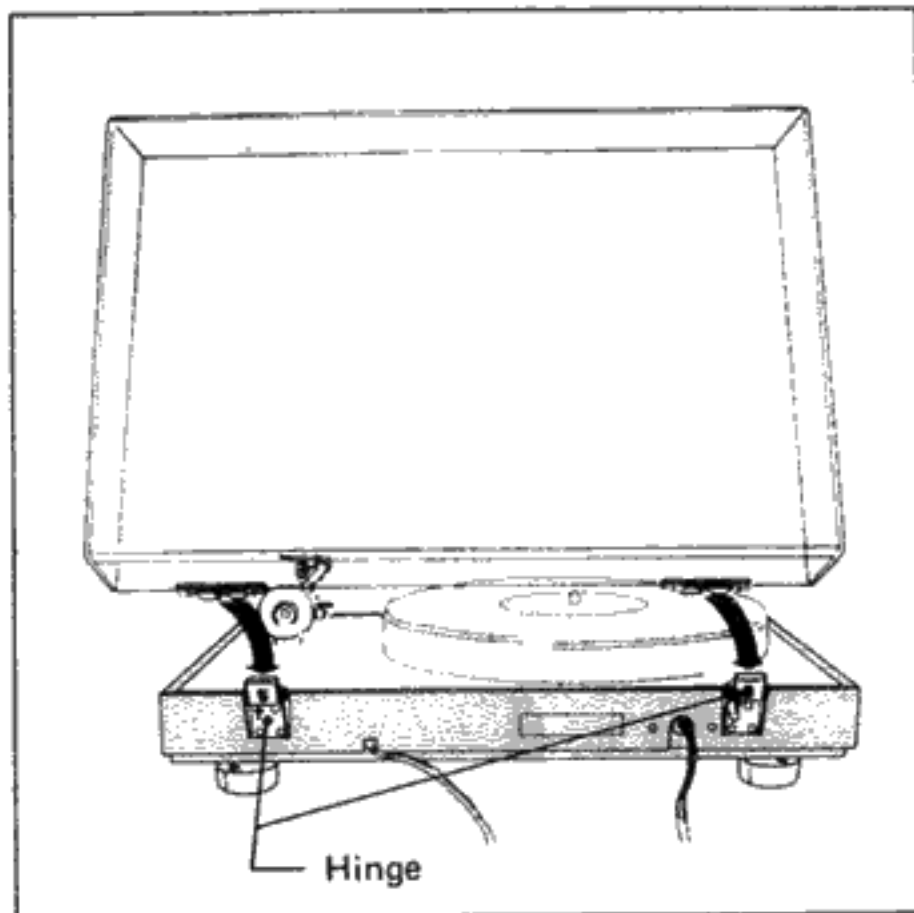

ADJUSTMENT OF TONEARM

1. Horizontal-Balance Adjustment

Remove the tonearm from the arm-rest to let it be free. To protect the stylus, hold the shell by fingers. Now rotate the rear part of the counter-weight until the "0" indication comes to the index line on the tonearm, where rotation stops. Then slide the main-weight back and forth to realize

horizontal balance of the tonearm. At this time, loosen the screw on the weight, and fix it again when finished.

2. Cartridge-Height Adjustment

When the stylus of the cartridge is put on the surface of a disc on the turntable, the tonearm should rest horizontal. There are many different cartridges in the marketplace, and in case the height of your cartridge is too low to obtain the horizontal balance of the tonearm, use the attached cartridge spacer. Three pieces of 1mm-thick spacer are provided. Insert the spacer between the cartridge and the head-shell.

3. Stylus Pressure Adjustment

Rotate the latter part of the counter-weight in the direction that the weight shifts to this side (counter-clockwise direction, seen from front). Be careful not to move the main-weight. Thus, obtain the necessary stylus pressure. The stylus pressure can be adjusted from 0g to 3g for cartridges ranging from 4g to 11g in weight.

4. Anti-skating Adjustment

The value of skating-force differs by the form of the stylus-tip of a cartridge, the material of the disc, etc.

When the canceller-weight of the PD277 is set to the root, it corresponds to 0.5g stylus pressure. And it corresponds to heavier pressure as the weight approaches the end of the bar. One scale is equivalent to 0.5g increment. Therefore, choose an appropriate position according to the stylus pressure of the cartridge.

5. Cueing Function Adjustment

The height of cartridge may be various, therefore, even when the tonearm is adjusted to be horizontal, it is possible that the tonearm will not be lifted up even when the elevation lever is operated. In this case, adjust two screws provided on the tonearm base so that the height of the elevation arm may become optimum.

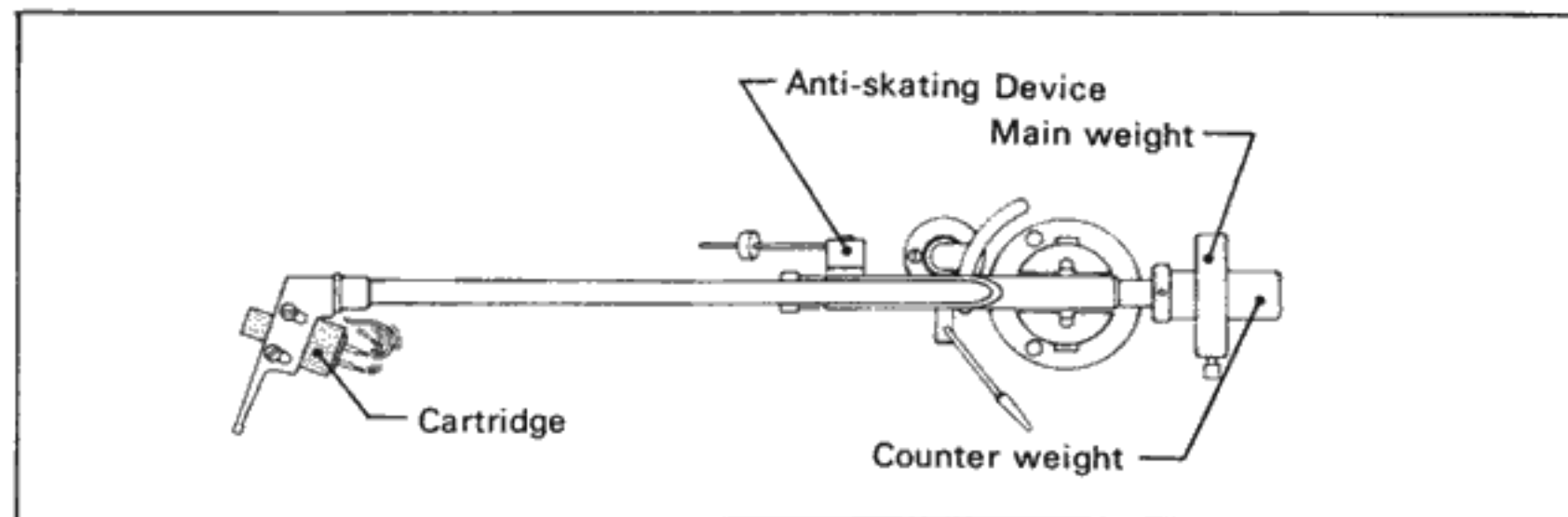

NAME AND USE OF EACH PART

1. AC Power Cord

Connect the AC plug at the end of the AC power cord to a wall socket in your listening room or to an extra AC outlet of an audio amplifier.

2. Phono Pin-Plug Cord

Connect the pin-plug to a PHONO terminal of the audio amplifier.

3. Earth Cord

Connect this cord to an earth terminal (GND) of the audio amplifier.

4. Tonearm Elevation (Cueing System) in the Case of Manual Operation

This moves the tonearm up and down by means of hydro-pressure. With the lever lifted up, bring the tonearm towards the disc so that the stylus-tip is above the groove of the disc, and then lower the lever. The tonearm will come down slowly

and smoothly until the stylus is in the groove. When the lever is lifted up, the tonearm will gently come up from the surface. Now it is possible to reset the tonearm at the arm-rest without damaging the disc.

Note that this lever has to be lowered for automatic and repeat playback operation.

5. Tonearm Rest

This provided to hold the tonearm when no playback is in progress. The tonearm clamp is also provided to prevent the stylus from any accidental damage.

6. Power Switch & Speed Selector

This switch offers two functions: it selects rotation speed between 33rpm and 45rpm, while deciding the dropping point of the stylus after automatic movement of the tonearm. At the same time it turns on the AC power when switched to either of the "45" and "33" positions. This switch should be set to the "off" position when you do not use the PD277, as otherwise the AC power is always supplied.

7. Function Switch

Three positions are provided; "repeat", "auto" and "manual". Normally, set the switch to the "auto" position. In this position, when the Automatic Start Button (8) is depressed, the tonearm automatically starts playing record and returns to the arm rest at the end of playback. The platter stops rotating. In the "repeat" position, the playback is endlessly repeated until the Automatic Cut Button (9) is depressed. While, in the "manual" position, the auto-

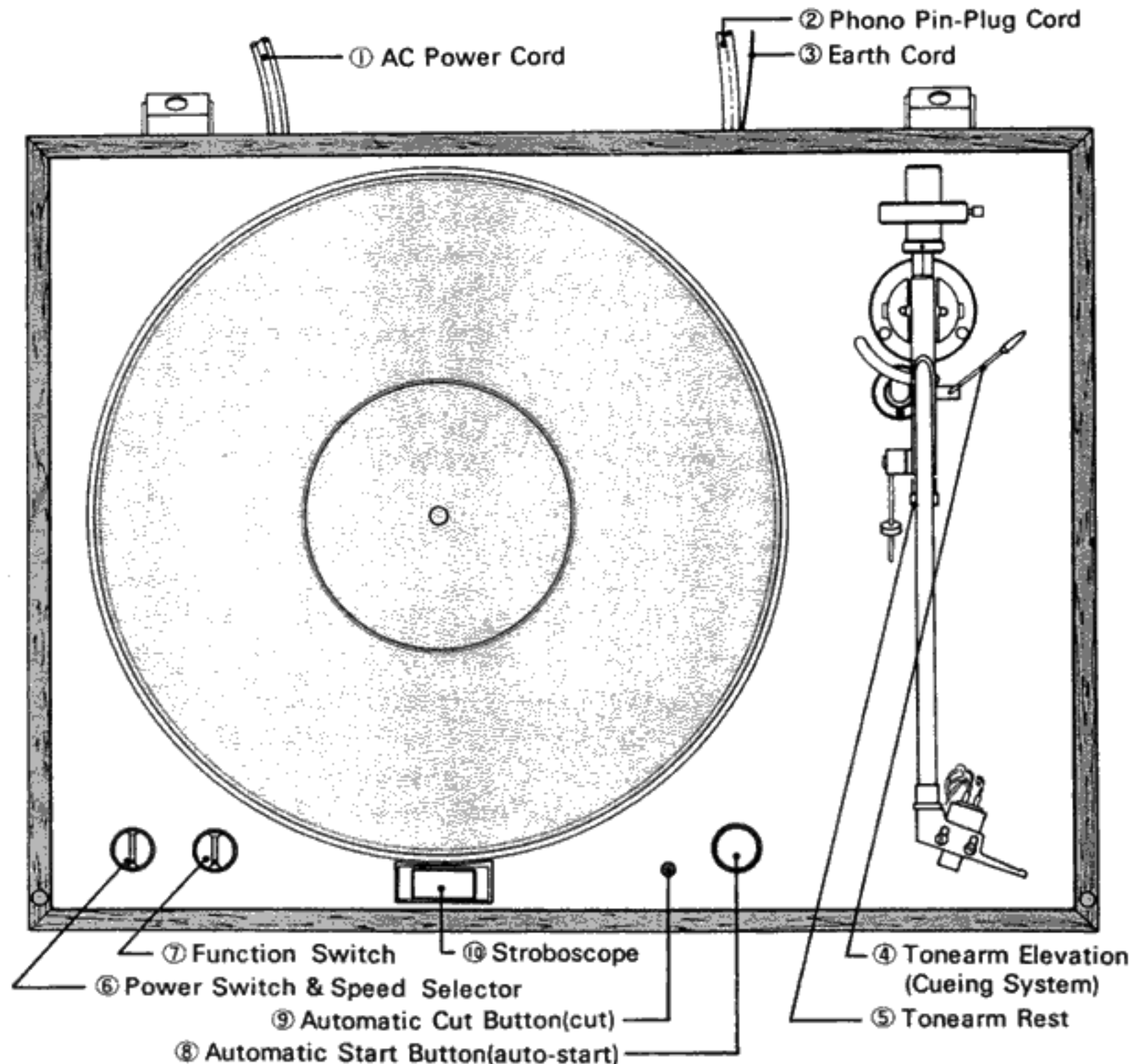

① AC Power Cord

② Phono Pin-Plug Cord

③ Earth Cord

⑦ Function Switch

⑩ Stroboscope

⑥ Power Switch & Speed Selector

⑨ Automatic Cut Button(cut)

⑧ Automatic Start Button(auto-start)

④ Tonearm Elevation (Cueing System)

⑤ Tonearm Rest

OPERATION PROCEDURE

[Auto-Play Operation]

1. Check that all the connections and the setting of the PD277 are correctly made.
2. Also check that the lever of the Tonearm Elevation (cueing system) is kept lowered, as otherwise the cartridge will not down.
3. Put a record on the platter. In case you use a large center hole record, set the adapter provided to the turntable shaft.
4. Set the Speed Selector to the "33" or "45" position according to the specified speed of the record, and the AC power is turned on. Note that in the "33" position you can play 30cm(12") LP records only. While, in the "45" position, the size is limited to 17cm ones. Therefore, in case you are to play such special discs of 30cm/45 r.p.m. (or 17cm/33 r.p.m.) sometimes available in the market place, the "manual" operation has to be selected by the Function Switch (7).
5. Set the Function Switch (7) to the "auto" position.
6. Depress the Automatic Start Button (auto-start), and the platter commences rotation. In about 5 seconds, the tonearm will automatically move to the starting position, and will come down slowly on the record surface to begin playback.
7. When playback is over, the tonearm will be automatically lifted up and come back to the Tonearm Rest, and then the rotation of the platter ceases.
8. If you wish to stop playing in the course

of playback operation, depress the Automatic Cut Button. The tonearm will automatically return to the Tonearm Rest, and the platter stops rotating.

9. After you finish your desired playback, set the Power Switch & Speed Selector to the original "off" position to turn off the AC power.

[Repeat-Play Operation]

1. In this mode of operation, playback of disc is endlessly repeated.
2. Check that the lever of the Tonearm Elevation (cueing system) is kept lowered.
3. Set the Power Switch & Speed Selector in the same way as described in the step (4) of the [Automatic-Play Operation].
4. Set the Function Switch (7) to the "repeat" position.
5. Depress the Automatic Start Button (8), and the tonearm starts to move automatically in the same manner as started in the step (6) of the [Automatic-Play Operation].
6. If you wish to stop playing, depress the Automatic Cut Button, and the tonearm automatically returns to the Tonearm Rest. At the same time, the "repeat" mode is released.

[Manual-Play Operation]

1. In this mode of operation, all the automatic functions are released, and only manual operation is feasible.
2. Check that the lever of the Tonearm Elevation is kept lifted up.
3. Set the Power Switch & Speed Selector to select the required speed.
4. Select the "manual" position by the

Function Switch (7). When the switch is set to this position, both of the Automatic Start Button (8) and Automatic Cut Button (9) are released as these two functions are exclusively effective for use of automatic operation.

5. Bring the tonearm horizontally towards the disc, and the platter commences rotation. Set the stylus above the disc, and lower the lever of the Tonearm Elevation. The stylus comes down slowly on the disc.
6. Note that in the "manual operation" mode, the tonearm will not automatically return to the Tonearm Rest. When playback is over, lift up the lever of the Tonearm Elevation and bring the tonearm back to the Tonearm Rest. Meanwhile rotation of the platter automatically stops.

CAUTION

- (1) When you install a cartridge to the Head Shell, centering of the stylus of the cartridge should be made precisely, as otherwise dropping point of the stylus may be inaccurate.
- (2) On the bottom side of the PD277, an Adjustment Screw is provided, which controls the dropping point of the stylus. Do not touch this screw since it is preset at the factory at the optimum position.

SPECIFICATIONS

[Phono Motor Section]

- * Driving System: Direct-Drive System
- * Motor: DC-servo brushless & slotless motor
- * Turntable Platter: 30cm aluminium die-cast
(weight 1.8kgs including platter-mat)
- * Rotation: 33-1/3 rpm, 45 rpm (2-speed)
- * Adjustable Range of Rotation: $\pm 4\%$
- * S/N Ratio: better than 60dB (IEC-B)
- * Wow & Flutter: no more than 0.03% W.R.M.S.

[Tonearm Section]

- * Tonearm: Straight Arm of static balance type
- * Effective Length: 240 mm
- * Tracking Error: $+2^{\circ} 13'$, $-1^{\circ} 08'$
- * Overhang: 15 mm
- * Cartridge Weight: 4g - 11g
- * Cartridge Height: 16mm ~ 19mm (by use of spacers)
- * Stylus Pressure: 0 - 3g (direct reading)
- * Accessories: Anti-skate adjustment, Tonearm Elevation

[Cartridge]

- * Generating System: Dual Magnet
- * Optimum Tracking Force: 2.5g
- * Frequency Response: 20Hz ~ 20,000Hz
- * Output Voltage: 5.0mV
- * Load Resistance: 47k ohms
- * Weight: 4.9g
- * Replacement Stylus: N-2700

[Additional Features]

- * Dust Cover: Detachable with semi-freestop hinge
- * Stroboscope: Mirror-reflex type
- * Automatic Function: Auto-Start, Auto-Cut and Auto-Repeat

[General]

- * Power Consumption: 8W
- * Dimensions: 472(W) x 152(H) x 348(D) mm
(18-37/64" x 6" x 13-45/64")
- * Weight: Net 10kgs (22 lbs.)
Gross 12kgs (26.4 lbs.)

Specifications and appearance design subject to change without notice.

LUX CORPORATION, JAPAN

1-1, 1-CHOME, SHINSENRI-NISHIMACHI, TOYONAKASHI,
OSAKA, JAPAN PHONE: 06-834-2222 TELEX: J63694

LUX AUDIO OF AMERICA, LTD.

160 DUPONT ST. PLAINVIEW, NEW YORK 11803 U.S.A.